

David Thomas and two pale boys Contract Rider, Concert EU 8/29/8

This document forms part of the contract. It is important.

NUMBERS YOU NEED TO KNOW

In the tour party: SIX

Who are vegetarians: TWO

Separate monitor mixes required: FIVE

Our VAT number is GB 494 2524 31

MANAGEMENT: directors@ubuprojex.net

Press, photos & promo materials:

<http://www.ubuprojex.net/resources.html>

AGENT: Berthold Seliger.

Tel: +49-(0)30-60031440 • Email: bs@bseliger.de

Fax: +49-(0)30-60031448

PRODUCTION REQUIREMENTS

Time: Running time is 60 minutes plus encores.

- We require 90 minutes unrestricted soundcheck from the point the PA & stage gear are setup and working.

Transport:

- Provide free, secure & legal parking for our tour vehicle with access to venue.
- Provide free local transport, including transport to & from the airport, to & from the hotel & venue, and to & from any shops required for production.

Venue:

- Provide up to 10 guest passes.
- Ensure that no commissions, fees or charges will be levied against our merchandise sales.
- We sell merchandise from the front of the stage after the show. If this is going to be a problem [inform us](#).
- Provide a private, lockable dressing room with access to a private & clean toilet.
- No recording or broadcast (including live video feed to screens inside the venue or any kind of webcasting) of the event is permitted without written [permission](#).
- All amendments to the rider must be authorized in writing by Management.
- Our fee is to be paid in full in cash before the show unless agreed in writing beforehand.

BILLING

The correct billing & the proper use of case is:
David Thomas and two pale boys

HOSPITALITY IN DRESSING ROOM

- Assorted sandwiches available at get-in and after the show, half vegetarian, half with meat.
- Fresh fruit, soft drinks, coffee with milk & sugar
- Bottle of Remy-Martin VSOP, at soundcheck.
- 5 liters of sparkling mineral water & 4 of still
- 1 bottle of red wine
- 28 bottles of cold beer
- Provide 3 large white clean towels

HOT MEAL AFTER SOUNDCHECK

Please provide a 3-course hot meal for the number of the tour party in or near the venue.

PA REQUIREMENTS

Please provide a 16 channel mixer with:

- Phantom power (+48 VDC).
- Direct outs or channel inserts on 8 channels.
- 4 subgroups and 4 Aux Send>Returns.
- 4 sweepable EQ bands on each channel.
- Provide 3 mono compressors (or 2 stereo), preferably DBX, BSS or Drawmer.

Please provide the following outboard:

- 3 noise gates.
- 2 multieffects processors, Lexicon or Yamaha.
- 1 Lexicon or similar vocal reverb.
- a CD player playable thru PA.

Please provide the following on stage:

- 6 (SIX) DI Boxes with LINK outs.

Find stage plot attached, for inputs & further needs.

MONITORING REQUIREMENTS

- 3 separate mixes into 4 stage wedges.
- Provide a qualified monitor engineer.

BACKLINE REQUIREMENTS

- 1 Roland JC120 amp
- 1 Fender Twin Reverb amp

STAGE REQUIREMENTS

- 1 (ONE) music stand with light.
- A table very close to the following dimensions: 3.5 feet wide by 2.5 feet deep by 2.75 feet high.
- A chair without arms on stage.
- The Fender Twin amp must be elevated 4 feet & the JC120 must be elevated 3 feet.

LIGHTS

We are always happy when the lights are simply set, focused, turned on & left during the show. Light scenes can shift but avoid rapid flashing. No smoke-machines are to be used.

Stage must NEVER fade to black between songs.

HOTEL REQUIREMENTS

- The exact number of rooms to be paid for by the promoter will be advised by our agent but will be, at the minimum, the number of the tour party.
- At least one of the rooms must have a kingsize bed for Mr Thomas.
- All rooms must have en-suite bathrooms, a phone and television
- The hotel must be minimum 3 star with a lift unless the rooms are on the ground floor
- HOTELS MUST PROVIDE SECURE PARKING FOR OUR TOUR VEHICLE.
- The booking must include full breakfast
- We are responsible for any hotel extras (phone, minibar and laundry); the promoter must pay for the rooms, breakfasts, parking and any taxes.

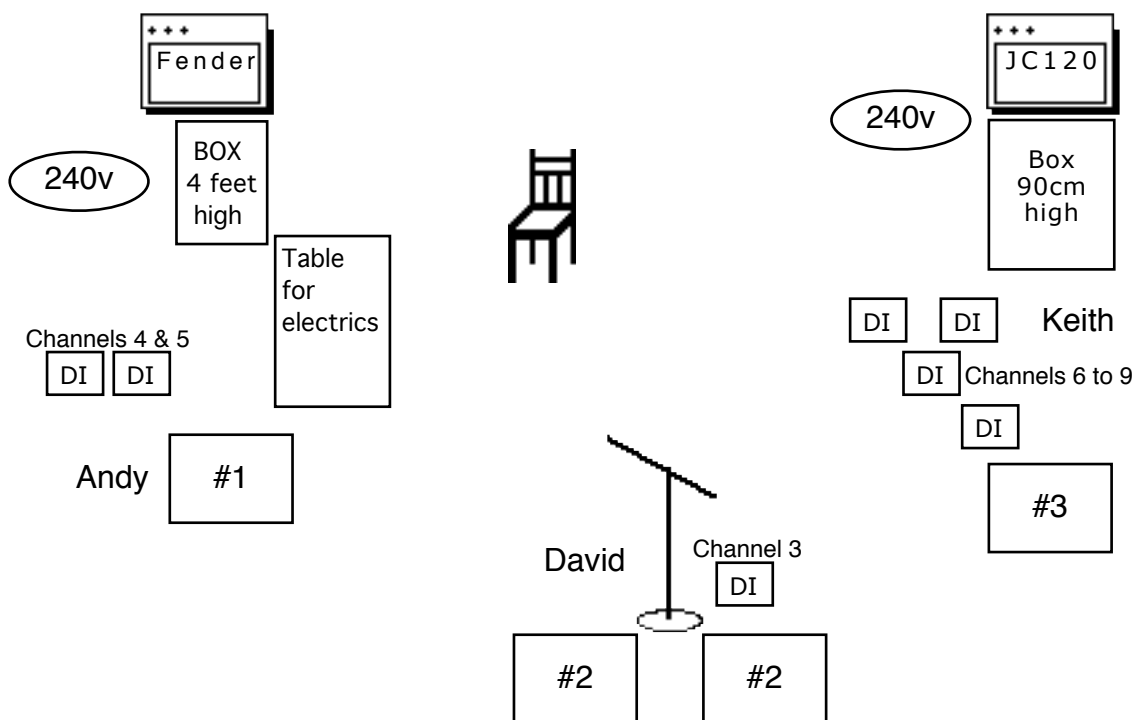

NB. Place music stand at Center Vocal position.
 Provide an XLR cable at Center Mic for our Telephone Mic.
 Provide 3 (THREE) Monitor Mixes as shown.
 The amps are NOT mic'ed. They are for on-stage monitoring only.
 The DI Boxes must have LINK OUTS.

Lines	Desk Inputs	Inserts
1	Vocal Mic (David) - Shure Beta58	compressor
2	Phone Mic (David) - we provide	compressor
3	Melodeon DI (David)	
4	Trumpet DI (Andy)	compressor
5	Loop FX DI (Andy)	
6	Roland #1 DI (Keith)	
7	Roland #2 DI (Keith)	
8	Mini Disk DI (Keith)	
9	Zoom DI (Keith)	